

# STELTEC

V4.1-2025-08



**STE-BWO-6140**



## STE-BWO-6140 Operation Manual

### CONTENTS

<b>1. Technical Specification</b>	1-2
<b>2. Safety Information</b>	
2.1 General Safety	3
2.2 Personal Safety	3-4
2.3 Electrical Safety	4-6
2.4 Transportation Safety	6
<b>3. Product Overview</b>	
3.1 Brief Introduction	7
3.2 Interface Introduction	8
3.2.1 Switch ON/OFF	8-9
3.2.2 LED Indicator Definition	9-10
3.2.3 CAN / RS485 Port	10
3.3.4 RS232 Port	10
<b>4. Installation guide</b>	
4.1 Checking Before Installation	11
4.1.1 Checking Outer Packing Materials	11
4.1.2 Checking Deliverables	11
4.2 Tools	13
4.3. Installation environment requirements	13
4.3.1 Installation carrier requirements	13
4.4 Installation Instructions	14
4.4.1 Dimensions	14
4.4.2 Installation Procedure	15-20
<b>5. Commissioning Procedure</b>	21
<b>6. Maintenance</b>	
6.1 Recharge Requirements During Normal Storage	22
6.2 Recharge Requirements When Over Discharged	22

## 1. Technical Specification



<b>Product Type</b>	<b>Flex-L4</b>
<b>Battery Model</b>	STE-BWO-6140
<b>Battery System Capacity</b>	6.14kWh
<b>Cell Technology Battery</b>	Li-ion(LFP)
<b>Cell Capacity Usable</b>	120Ah
<b>Capacity Configuration</b>	5.53kWh
<b>Nominal Voltage</b>	1P16S
<b>Operating Voltage</b>	51.2V
<b>Range</b>	45.6~56.2V
<b>Dimension(W*D*H)</b>	578*225*471mm
<b>Net Weight</b>	65kg
<b>Scalability</b>	Max. 15 systems in parallel operation
<b>Installation</b>	Wall mounted only
<b>Depth of Discharge</b>	90%
<b>Charge/Discharge Current(Recommended)</b>	60A
<b>Charge/Discharge Current(Max)</b>	100A
<b>Cooling Method</b>	Natural convection
<b>Communication Port</b>	RS232, RS485, CAN
<b>Protection Class</b>	IP65
<b>Environment</b>	Indoor or Outdoor Eaves
<b>Charging Temperature</b>	-20°C~55°C (with heating) 0°C~55°C (without heating)
<b>Discharging Temperature</b>	-20°C~55°C
<b>Humidity</b>	5%-95%
<b>Max. Operating Altitude</b>	2,500m
<b>Wi-Fi Module</b>	Built in Wi-Fi module, APP OTA function
<b>Extended Functions</b>	Thermal aerosol fire extinguishing device(standard) Heating system (optional)
<b>Certificates</b>	IEC62619 / IEC61000 / CE / UN38.3 / MSDS



## 2. SAFETY INFORMATION

### 2.1 General Safety

Please carefully read the manual safety precautions and observe all the safety instructions on the equipment and in this document.

The "DANGER", "WARNING", and "NOTICE" statements in this document do not cover all the safety instructions. They are only supplements to the safety instructions.

For user safety and utilization efficiency of this manual, a list of symbols is designed to alert people from danger. You must understand and comply with the emphasized information to avoid personal injury and property damage. Relative safety symbols have been listed below.

 <b>Danger</b>	DANGER indicates a hazardous situation which, if not avoided will result in serious injury and/or fire.
 <b>Warning</b>	WARNING indicates a hazardous situation which, if not avoided, will result in property loss and/or void the warranty.
 <b>NOTICE</b>	NOTICE indicates normal situation which, if not avoided, will result in damage to the battery.

### NOTICE

Follow local laws and regulations when installing, operating, or maintaining the equipment. The safety instructions in this document are only supplements to local laws and regulations.

### 2.2 Personal Safety

#### Personal Requirements

People who plan to install or maintain battery equipment must be trained, understand all necessary safety precautions, and are able to correctly perform all operations.

Only qualified professionals or trained people are allowed to install, operate, and maintain the equipment.







### **▲ DANGER**

- Do not place battery in an area accessible by children or pets.
- Do not touch the energized battery, the temperature of the battery enclosure may increase during operation.
- Do not touch the energized battery terminals.
- Do not stand on, lean on, or sit on the battery.

### 2.3 Electrical Safety

#### Symbols on Battery

There are some electrical symbols on battery relate to electrical safety. Please make sure you have fully understood them before installation.

	Electrical danger	Voltage exists when the battery is powered on. Only qualified engineers are allowed to operate.
	Earth connector	Earth connection.
	DC positive and negative connectors	Identify positive and negative connectors of DC power source.
	CE mark	The product meets CE certification.
	WEEEtag	Batteries must not be disposed with general waste. It must be appropriately recycled in accordance with local regulations.
	Recycle	Batteries can be recycled, please refer to your local regulations regarding the correct disposal methods.

## Electrical Safety

### **⚠ DANGER**

- Before installation, ensure that the equipment is intact. Otherwise, electric shocks or fire may occur.
- Do not connect or disconnect power cables when battery is power-on. Which may cause electric arcs and sparks more over fire or personal injury.
- Before connecting a power cable, check the positive or negative connectors are correct.
- Do not parallel connection with different batteries.
- Do not connect battery with AC directly.
- Do not connect battery with PV wiring directly.
- Do not connect battery to faulty or unqualified inverter or charger.
- Do not create short circuits with the external connection.
- Make sure the grid is cut off and the battery is powered off before maintenance.
- Make sure the earth cable is connected correctly before operation.

### **⚠ WARNING**

- Recharge battery in every six months if not in use.
- Recharge battery within 10 days after battery is fully discharged(SOC=0%).
- Ensure battery cable is installed correctly.
- When the battery is being installed or repaired, ensure the battery is powered off and and isolated. Using a multimeter check to ensure there is no voltage in the positive and negative terminals.

### **⚠ CAUTION**

- Please use appropriately insulated tools for installation and maintenance.
- Please check the LED status when the battery is powered on.
- Please ensure the communication cable is connected correctly between the battery and the inverter.
- Please check for inverter alarms and the SOC reading once communication is established between the inverter and the battery.

## Environment Safety

### **⚠ WARNING**

- Ensure the battery is installed in a dry and well-ventilated location.
- The installation position must be away from direct sunlight and rain.
- The installation position must be far away from potential sources of fire..
- The installation position must be far away from all sources of water.
- Do not install the equipment in locations that contain flammable gases and/or flammable liquids.
- The operation and service life of the battery depends on the operating temperature. Operate the battery at a temperature equal to or better than the ambient temperature. The recommended operating temperature range is from 0°C to 30°C.

## 2.4 Transportation Safety

### **⚠ WARNING**

- The products have passed UN38.3 certification.
- The products have MSDS documents available.
- The products belong to class 9 dangerous goods.
- **Please protect the packing case from the below situations:**
  - Being dampened by rains, snows, or falling into water.
  - Falling down or mechanical impact.
  - Being upside-down or tilted.

## 3.PRODUCT OVERVIEW

### 3.1 Brief Introduction

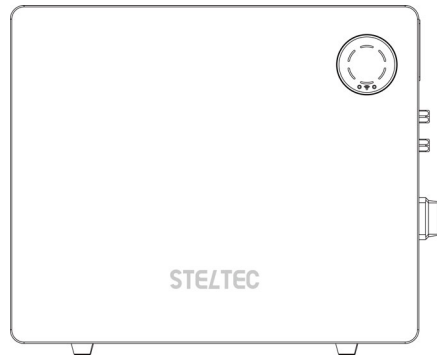

Flex-L4 is a lithium battery with an operating voltage range between 45.6~56.2V. It is designed for residential energy storage applications and works together with a low voltage hybrid inverter. **Flex-L4 is not suitable for supporting life-sustaining medical devices.**

Flex-L4 has built-in BMS (Battery Management System), which can manage and monitor cells information including voltage, current and temperature. Besides that, BMS can balance cells charging to extend cycle life. BMS has protection functions including over-discharge, over-charge, over-current and high/low temperature; the system can automatically manage charge state, discharge state and balance state.

Multiple Flex-L4 can be connected in parallel to expand capacity and power, 15 Flex-L4 can be connected in parallel at most.

**Note: For multiple batteries in parallel, only the Master battery SOC LED will be on to show the whole system SOC level, slave battery SOC LEDs are off, but the Normal&Alarm LED will show normally.**

### 3.2 Interface Introduction

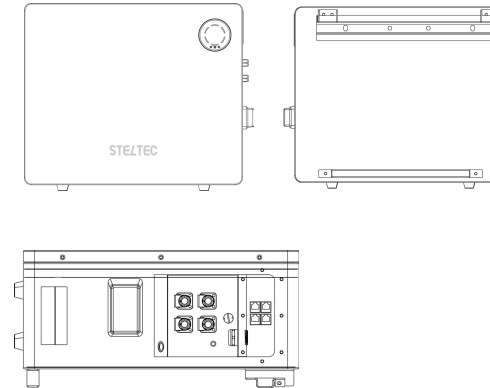

#### 3.2.1 Switch ON/OFF

##### 1. Switch ON

For single Battery Module, turn on the air switch, Long press (more than 3 seconds) ON/OFF button, Normal LED will be lighted in the front panel then battery will operate normally. L1 to L6 shows battery SOC, L7/L8 shows battery status.

For multiple Battery Modules in parallel, turn on the air switch of all batteries, long press (more than 3 seconds) ON/OFF button of master battery (Which connect with inverter), normal LED will be lighted, battery system will automatically encode and assign ID to each slave battery, then battery system will operate normally.

##### 2. Switch OFF

For multiple battery modules in parallel, turn off the air switch of all batteries, press ON/OFF button of master battery (which connect with inverter) more than 3s, LED will flash in the front panel and then release the button, the master battery will shut down after all slave batteries shut down(Sleep mode).

For single battery module, turn off the air switch, Long press (more than 3s) ON/OFF button, LED will flash in the front panel and then release the button, the battery will shut down.

## 3.2.2 LED Indicator Definition

Note:

flash 1 - 0.25s light / 3.75s off

flash 2 - 0.5s light / 0.5s off

flash 3 - 0.5s light / 1.5s off

### LED Indicators Instructions

Status		RUN	ALM	Battery Level Indicator						Descriptions	
				L6	L5	L4	L3	L2	L1		
Shut down	Sleep Mode	OFF	OFF	OFF	OFF	OFF	OFF	OFF	OFF	OFF	All OFF
Standby	Normal	Flash 1	OFF	According to the battery level						Indicates Standby	
	Alarm	Flash 1	Flash 3	According to the battery level						Indicates Module Undervoltage Alarm	
Charging	Normal	Light	OFF	According to the battery level						The highest capacity indicator LED flashes(flash 2), ALM LED does not flash during overcharge alarm	
	Alarm	Light	Flash 3	According to the battery level							
	Full Charged Protection	Light	OFF	Light	Light	Light	Light	Light	Light	Light	Turn to standby status when charger off
Discharging	Temperature, Overcurrent, Fault Protection	OFF	Light	OFF	OFF	OFF	OFF	OFF	OFF	OFF	Stop charging
	Normal	Flash 3	OFF	According to the battery level							
	Alarm	Flash 3	Flash 3	According to the battery level							
Discharging	Under Voltage Protection	OFF	OFF	OFF	OFF	OFF	OFF	OFF	OFF	OFF	Stop discharging
	Temperature, Overcurrent, Short Circuit, Failure Protection	OFF	Light	OFF	OFF	OFF	OFF	OFF	OFF	OFF	Stop discharging
Fault		OFF	Light	OFF	OFF	OFF	OFF	OFF	OFF	OFF	Stop charging and discharging

L9 ON: Wifi connected successfully/ L9 OFF: Wifi connection failed or power OFF.

### Charging/Discharging Battery Level Indicators Instructions

Status	Charging						Discharging					
	L6	L5	L4	L3	L2	L1	L6	L5	L4	L3	L2	L1
Battery Level Indicator	ON	ON	ON	ON	ON	ON	ON	ON	ON	ON	ON	ON
Battery Level(%)	0%~17%	OFF	OFF	OFF	OFF	Flash 2	OFF	OFF	OFF	OFF	OFF	Light
	18%~33%	OFF	OFF	OFF	Flash 2	Flash 2	OFF	OFF	OFF	OFF	Light	Light
	34%~50%	OFF	OFF	Flash 2	Flash 2	Light	Light	OFF	OFF	OFF	Light	Light
	51%~66%	OFF	Flash 2	Flash 2	Light	Light	Light	OFF	OFF	Light	Light	Light
	67%~83%	OFF	Flash 2	Light	Light	Light	Light	OFF	Light	Light	Light	Light
	84%~100%	Flash 2	Light	Light	Light	Light	Light	Light	Light	Light	Light	Light
Running Indicator	Light						Flash 3					

## 3.2.3 CAN / RS485 Port

CAN / RS485 Communication Terminal (RJ45 port), connect to inverter, follow CAN / RS485 protocol.

PIN	Definition
Pin 1 Pin 8	RS485-B ( to PCS, reserved )
Pin 2 Pin 7	RS485-A ( to PCS, reserved )
Pin 3	NC
Pin 4	CANH ( to PCS )
Pin 5	CANL ( to PCS )
Pin 6	GND

## 3.2.4 RS232 Port

RS232 Communication Terminal (RJ45 port) follow RS232 protocol, for manufacturer or professional engineer to debug or service.

PIN	Definition
Pin 1 Pin 8	GND
Pin 2 Pin 7	RS232_TX
Pin 3 Pin 6	RS232_RX
Pin 4 Pin 5	NC

## 4.INSTALLATION GUIDE

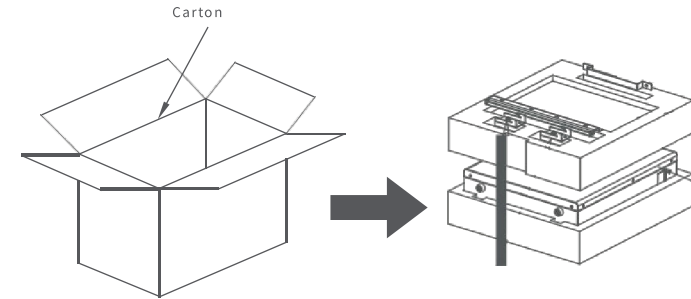
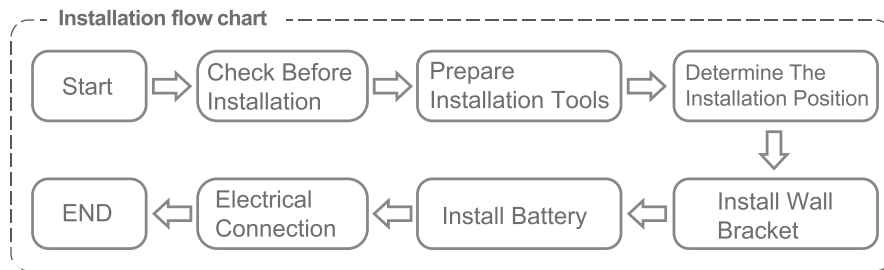

### 4.1 Checking Before Installation

#### 4.1.1 Checking Outer Packing Materials

Packing materials and components may be damaged during transportation. Therefore, check the outer packing materials before installing the battery. Checking the surface of packing materials for damage, such as holes and cracks. If any damage is found, do not unpack the battery and contact the dealer as soon as possible.

#### 4.1.2 Checking Deliverables

After unpacking the battery, check whether deliverables are intact and complete. If any damage is found or any component is missed, contact the dealer.









The below table shows the components and mechanical parts that should be delivered.

STE-BWO-6140 Packing List					
No.	Part no.	Part name/size	Quantity	Photo	Used for
1	1.02.005	Battery box	1		
2	3.01.0172	Wall mounting bracket 480*65*16_t=2mm	1		
3	3.01.0171	Hanging parts 80*50*28_t=2mm	2		
4	3.01.0173	Wall mounting support frame 426*30*20_t=2mm	1		
5	3.01.0190	Positive power cable plug RCL24X-120-25 orange plug	1		To parallel with multiple packs
6	3.01.0190	Negative power cable plug RCL24Y-120-25 black plug	1		To parallel with multiple packs
7	3.01.0271	V1.0-PSRP6XC25XA_1 red 4AWG extra soft silicone wire with a wire length of 1500mm-SC25-10 terminals	1		Power cable +
8	3.01.0272	V1.0-PSRP6XA25XA_1 black 4AWG extra soft silicone wire with a wire length of 1500mm-SC25-10 terminals	1		Power cable -
9	3.01.0133	Expansion screw_M8*80mm_8.8 grade 304 stainless steel	4		To lock Wall mounting bracket

STE-BWO-6140 Packing List					
No.	Part no.	Part name/size	Quantity	Photo	Used for
10	3.01.0034	Crossed external hexagonal triple combination screws_M8*15mm_8.8 grade 304 stainless steel	12		To lock hanging parts Grounding screw
11	3.01.0064	V1.0_RJ45 crystal plug_Black Super Class 5 Unshielded_T568B color line sequence_Line length 1500mm_RJ45 crystal plug	1		Communication cable between master pack and inverter or for parallel of multiple packs
12	3.01.0137	Yellow-green two-color grounding Cable	1		Grounding Cable
13	3.01.0098	Flat gasket M8 * 20 * 1.5mm_8.8 grade 304 stainless steel	2		Accessory gasket
14	3.01.0089	RJ45 Crystal head	2		RJ45 Crystal head
15	3.01.0094	Desiccant 2g moisture-proof desiccant	2		Moisture-proof
16		Outgoing Inspection Report	1		Outgoing Inspection Report
17		Battery Networking Guide	1		Battery Networking Guide

# STELTEC

## 4.2 Tools

Tools			
Installation	Knife 	Measuring tape 	Socket wrench (10/16mm) 
	Rubber mallet 	Cross Screwdriver 	Hammer drill (12mm) 
Protection	ESD gloves 	Safety goggles 	Anti-dust respirator 
	Safety shoes 		

## 4.3 Installation environment requirements

- **Recommended:** Install the battery in the indoor environment.
- Place battery in secure location away from children and animals.
- Do not place the battery near any heat sources and avoid sparks.
- Do not expose the battery to moisture or liquids.
- Do not expose the battery to direct sunlight.

### 4.3.1 Installation carrier requirements

- Only mount battery on fire resistant building. Do not install batteries on flammable buildings.
- Battery is quite heavy, make sure the wall/ground can meet the load bearing requirements.

## 4.4 Installation Instructions

### 4.4.1 Dimensions

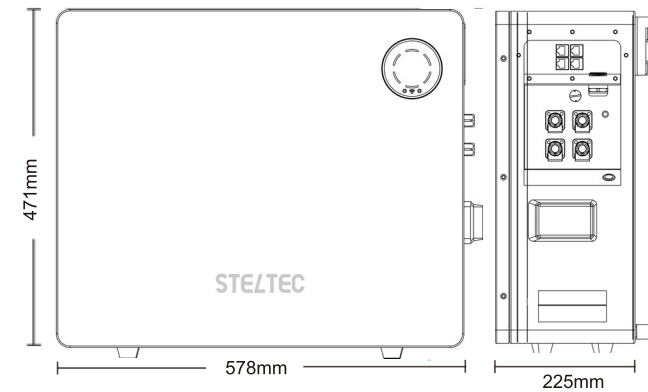

Minimum mounting distance between battery packs and walls:

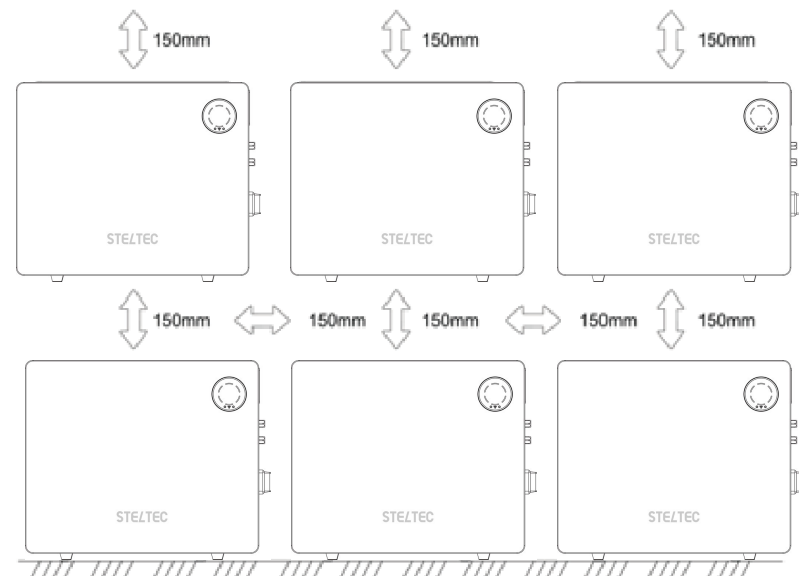

## 4.4.2 Installation Procedure

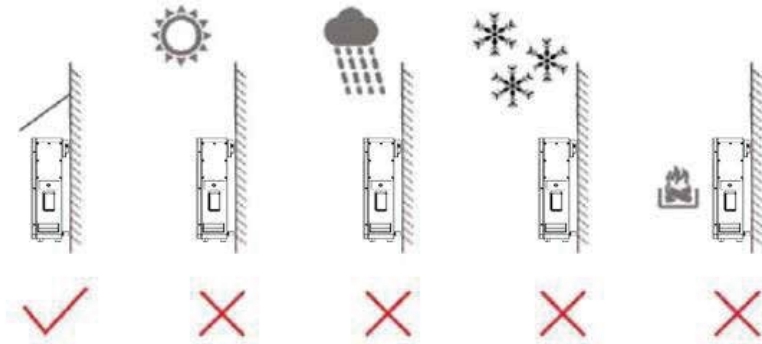

### STEP 1

Drill the hole with an 12 mm drill bit as follows and fix the wall mounting bracket to the wall.

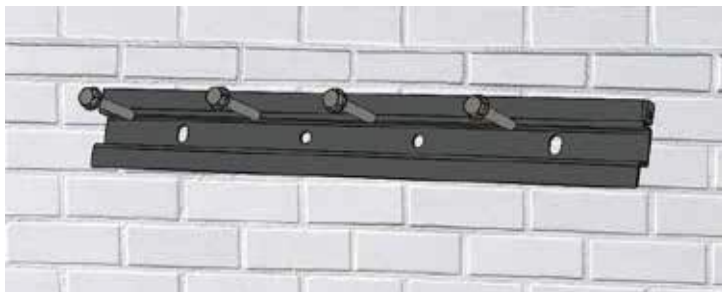

### STEP 2

Install the hanging parts.

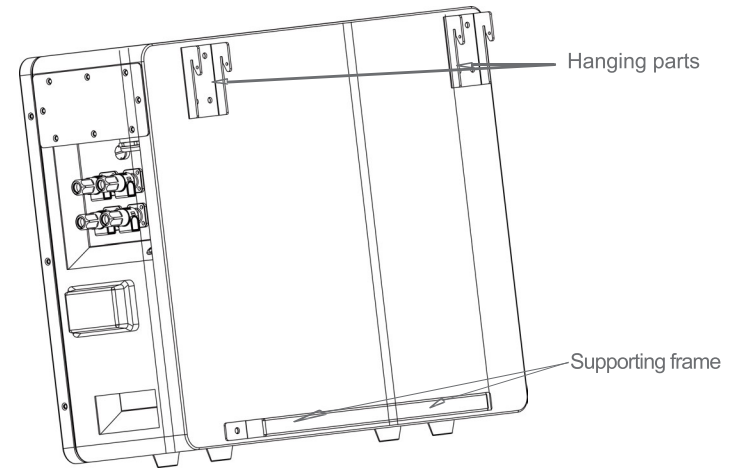

### STEP 3

Hang Flex-L4 on the wall wall mounting bracket and tighten it.

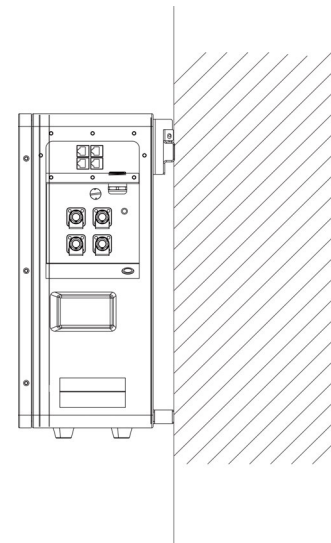

## STEP 4

Connect to ground.

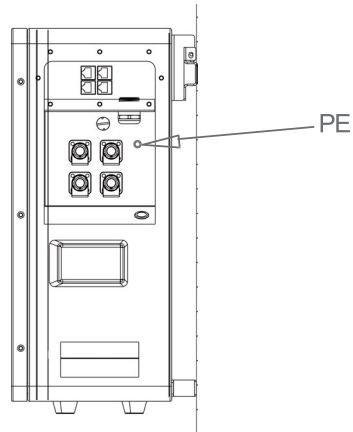

## STEP 5

Connect power cable.

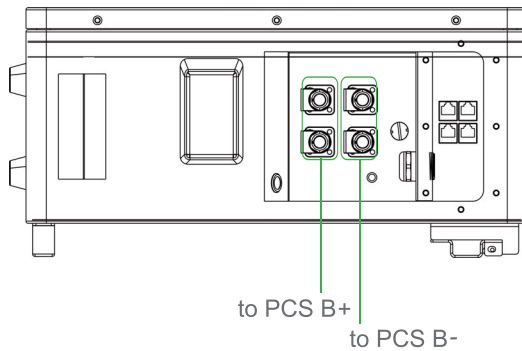

## STEP 6

Connect communication cable.

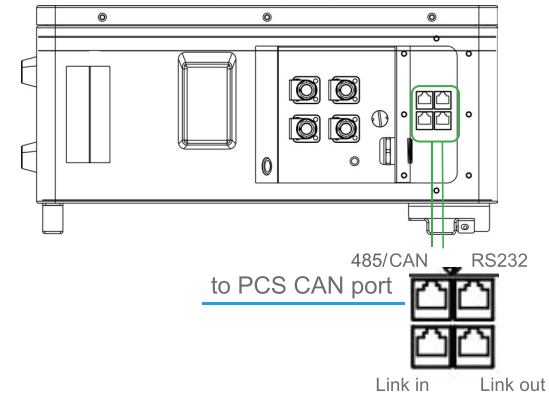

## STEP 7

1. Load power exceeding 5kW requires at least 2 units Parallel operation.
2. The maximum number of Number of parallel machines is 15. The power of the inverter selected for the battery module must be less than the maximum output power of the battery module.

Parallel operation	Load power	Connection mode
1unit	Below 5kW	7.1
2-15units	5kW or Below	7.2
2-15units	Over 5kW	7.3

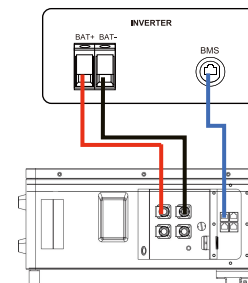

Cable connection in all the following views

- Lithium battery positive power cable
- Lithium battery negative power cable
- Lithium battery communication cable

**7.1** **Warning**  
Wiring method of 1 unit module with power below 5kW

# STELTEC

**Warning**

7.2

For 2 units -15 units is-layer module with power 5kW or below.  
 (The number of units in the middle of the diagram is omitted, the length of the two positive and negative poles connecting lines must be the same.)  
 All connection cables between the inverter and the battery must be kept at equal length to maintain proper system balance and reliable operation.

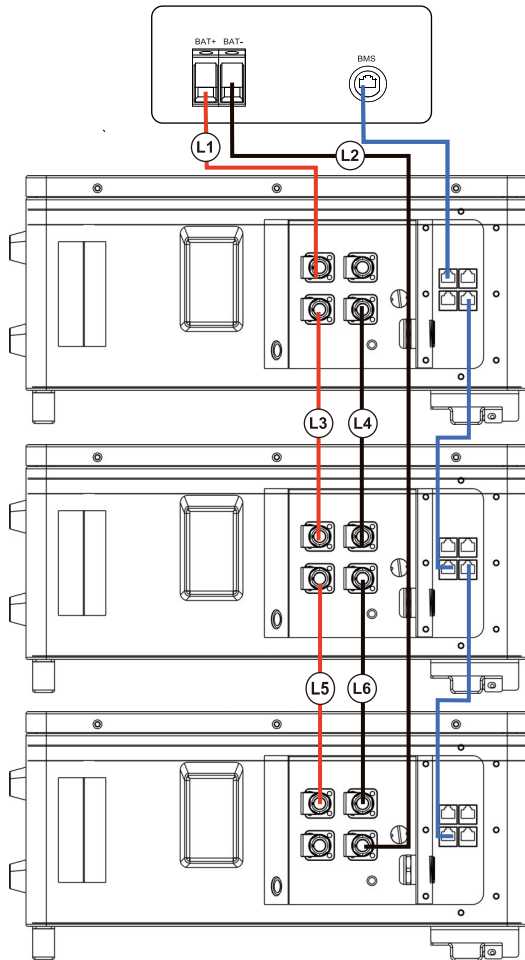

L: Length  
 L1=L2  
 L3=L4=L5=L6

**Warning**

7.3

When using an inverter of above 5kW, the positive and negative ports of each battery must be connected to the combiner cabinet in the wiring method shown in the figure below.  
 For 2 units -15 units is Over 5kW.  
 (The number of units in the middle of the diagram is omitted. In order to ensure equal current flow, the length of the positive and negative poles connecting lines must be the same.)

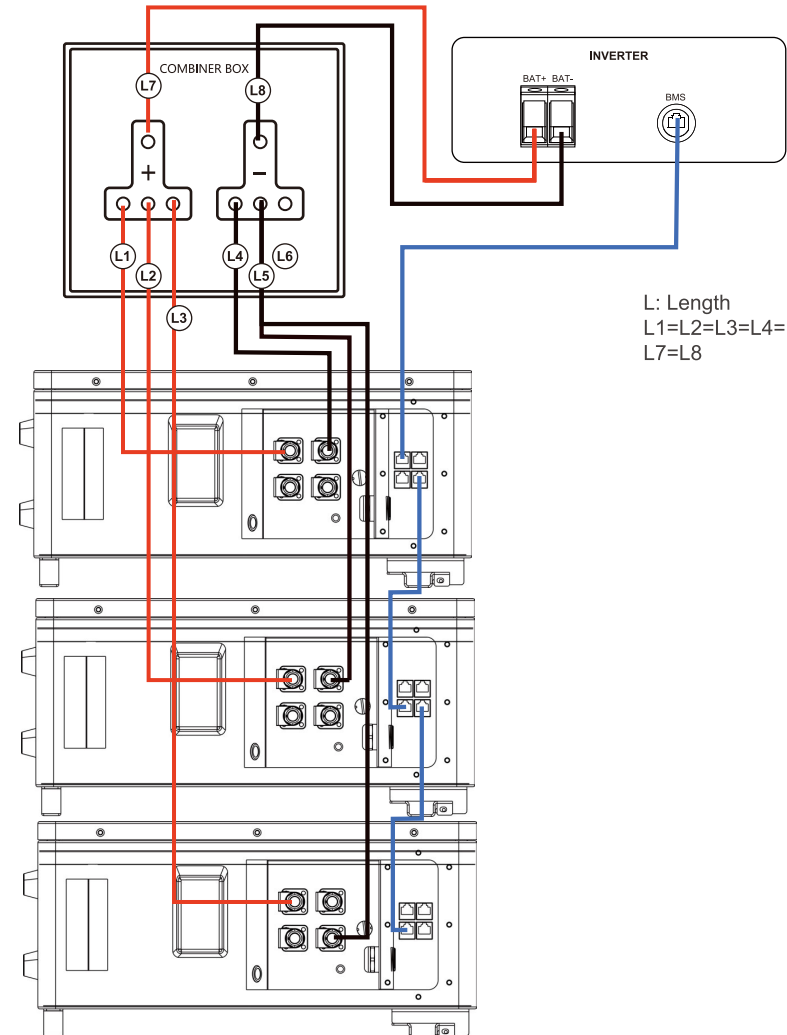

L: Length  
 L1=L2=L3=L4=L5=L6  
 L7=L8

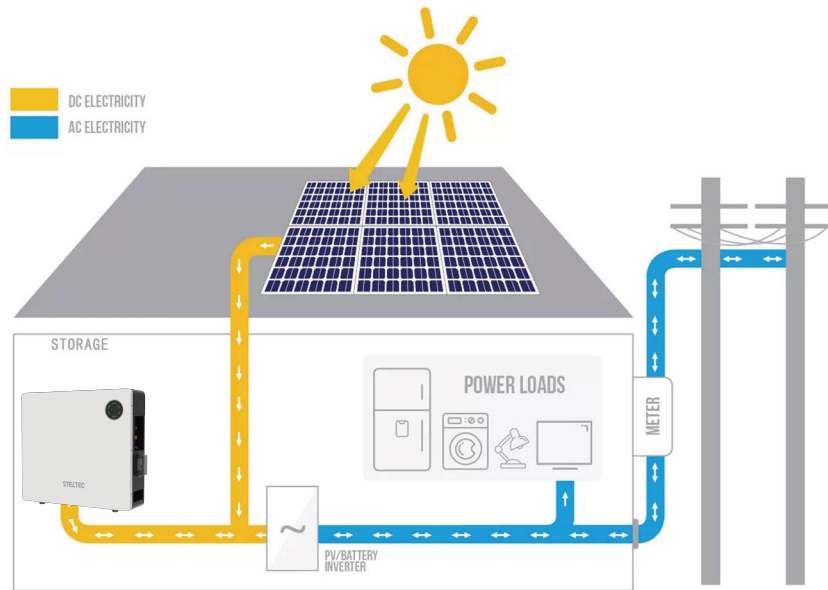

## 5. Commissioning Procedure

After all the cable (power and communication) connections are completed, please ensure the following:

- Ensure the DC switch on the inverter is OFF
- Ensure the AC switch that is connected to the grid and EPS output (if used) of the inverter is OFF
- Ensure the DC switch is OFF

For commissioning we recommend the following steps:

- Turn the DC switch ON
- Refer to section 3.2.1 Start for turning on the battery.
- Wait until the LED's on
- Wait until the inverter LED's on
- Turn the DC switch on the inverter ON
- Turn the AC switch that is connected to the grid and EPS output of the inverter ON
- Set-up the battery and the inverter using the App

## 6. MAINTENANCE

### 6.1 Recharge Requirements During Normal Storage

Battery should be stored in an environment with temperature range between -10°C ~+45°C, and maintained regularly according to following table with 0.5C (60A) current till 50% SOC after long storage time.

Recharge Conditions When In Storage

Storage Environment Temperature	Relative Humidity of Storage Environment	Storage Time	SOC
Below -10°C	/	prohibit	/
-10~25°C	5%~70%	≤12 months	30%≤SOC≤60%
25~35°C	5%~70%	≤6 months	30%≤SOC≤60%
35~45°C	5%~70%	≤3 months	30%≤SOC≤60%
Above 45°C	/	prohibit	/

### 6.2 Recharge Requirements When Over Discharged

Over discharged (90% DOD) battery should be recharged according to following table, otherwise over discharged battery will be damaged.

Recharge conditions when battery is over discharged

Storage Environment Temperature	Storage Time	Note
-10~25°C	≤15 days	Battery Pack disconnected from PCS
25~35°C	≤7 days	
-10~45°C	<12 hours	Battery Pack connected to PCS